

Model No. H44X



Name of parts	Material
Body	Ductile iron
Seat Ring	Bronze
Disc Sealing Ring	EPDM
Disc Plate	SS304
Disc	Ductile iron
Clapper Arm	Ductile iron
Bonnet Gasket	EPDM
Bonnet	Ductile iron
Hinge Pin	SS304
Hinge Bushing	Bronze
Hinge Plug	SS304

14

**Technical data** >

- Sizes: 2"-12"
- Working pressure: 300psi
- Valve standard: AWWA C508
- Flange standard: ASME-B16.1 Class125
- Temperature range: 0 ~ 80 °C

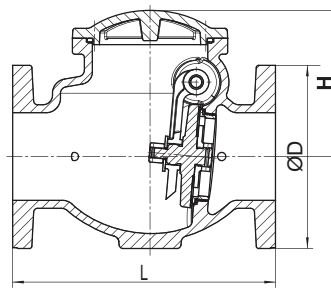

Size 2"-4"

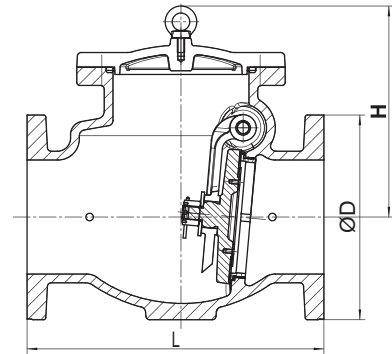

Size 5"-12"

Dimensions		Pressure rating	Size (mm)		
DN	inch		psi	ΦD	L
50	2	300	152	203	125
65	2.5	300	178	254	139
80	3	300	191	279	153
100	4	300	229	330	184
125	5	300	254	356	275
150	6	300	279	406	289
200	8	300	343	495	352
250	10	300	406	559	411
300	12	300	483	660	480

Model No. H84X



Name of parts	Material
Body	Ductile iron
Seat Ring	Bronze
Disc Sealing Ring	EPDM
Disc Plate	SS304
Disc	Ductile iron
Clapper Arm	Ductile iron
Bonnet Gasket	EPDM
Bonnet	Ductile iron
Hinge Pin	SS304
Hinge Bushing	Bronze
Hinge Plug	SS304

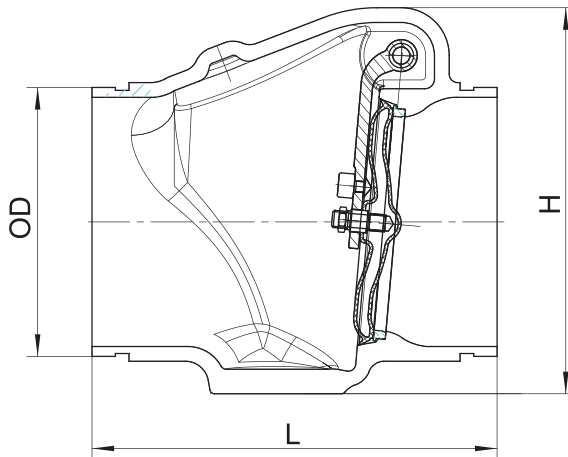

**Technical data >**

- Sizes: 2"~12"
- Working pressure: 362psi
- Grooved standard: AWWA C606
- Temperature range: 0 ~ 80 C

Dimensions		Pressure rating	Size (mm)		
DN	inch		psi	OD	L
50	2	362	60.3	167	122.5
65	2.5		73		
		76.1	180	136.5	
80	3	362			88.9
100	4		114.3	229	193.6
125	5	362	139.7		
			141.3		
150	6	362	165.1	272	252
			168.3		
200	8	362	219.1	330	314.5