

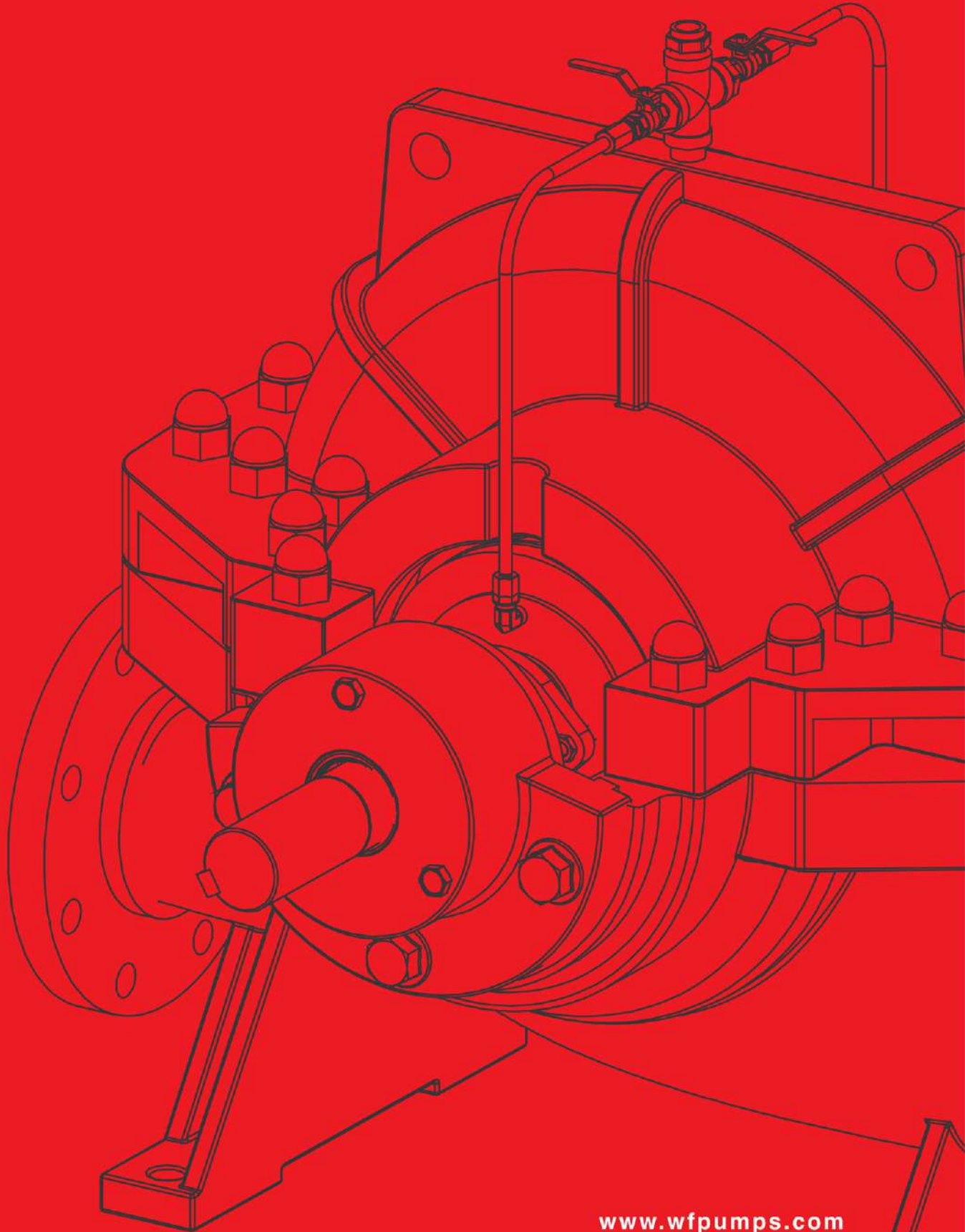

# WATERFALL PUMPS MANUFACTURING





**WATERFALL  
PUMPS  
MANUFACTURING**





Our Vision for the future is to become the world's premier provider of fire protection pumps.

Our ongoing mission is to be the customer's first choice, a trusted provider and global leader of fire protection pumps.

Being a global leader enables us to provide valued solutions, quality products and services, in a cost effective manner to satisfy the needs of our clients.

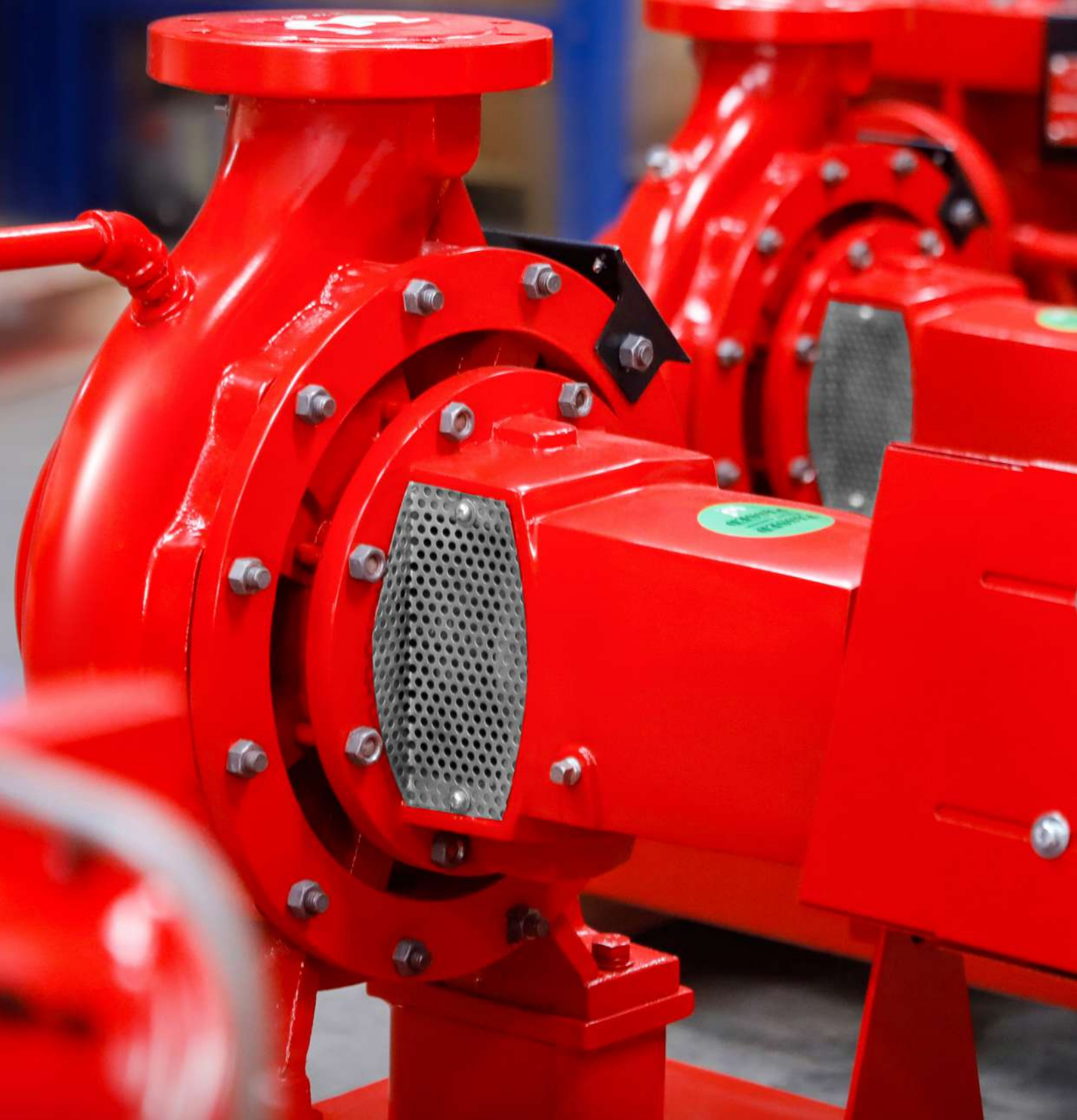
# PRODUCT OVERVIEW





WATERFALL is an innovative and efficient centrifugal Pumps Manufacturer that offers operators of pumps systems a wide range of quality products.

Our product line complies with the most demanding quality standards and industry specifications and built as per NFPA 20 and listed by Underwriters Laboratories / Factory Mutual.

WF Horizontal Split Case Pumps offer higher efficiencies, more reliable operation and low maintenance, constructed with double inlets that practically eliminate and thrust while boosting operation efficiency.

Their simplicity of design allows for inline service without disturbing piping and ensure long efficient unit life and minimum power consumption.

WF End Suction Pumps are engineered to last with a precision-cast, dynamically balanced and enclosed impeller that minimizes vibration and maximizes bearing life. Due to the back-pull-out design, the complete bearing assembly including impeller and casing cover can be dismantled without removing the volute casing from the pipe system.

WF pumps can be driven by either an electric motor or diesel engine with a full range of options and accessories available to complete the NFPA-compliant fire pump.

Heavy fabricated steel bases, are available to mount the pump and driver along with flexible coupling connects driver to pump. WF Split Case / End Suction Pumps are specified when the source of water is located above the surface of the ground and provide a positive suction pressure to the pump at any performance point.

Intensive research and development ensures that the products of WF Pumps are continuously improved to meet the latest technical requirements. Instant availability of spare parts, together with first class service, assures customer that they have selected the right partner.

A highly trained and experienced research team is backed by a fully equipped laboratory for conducting rigorous performance and endurance testing.

# SELECTION CRITERIA



According to NFPA20, the characteristic curve of fire pumps is defined by:

## **Shut-off head**

The Shut-off head shall not exceed 140 percent of rated head for any type of pump.

## **Rated Pressure / rated flow**

pump characteristic curve must pass through or above the point where rated flow rate and rated pressure values intersect each other.

## **Overload**

Pumps shall furnish not less than 150 percent of rated capacity at not less than 65 percent of the total rated head.

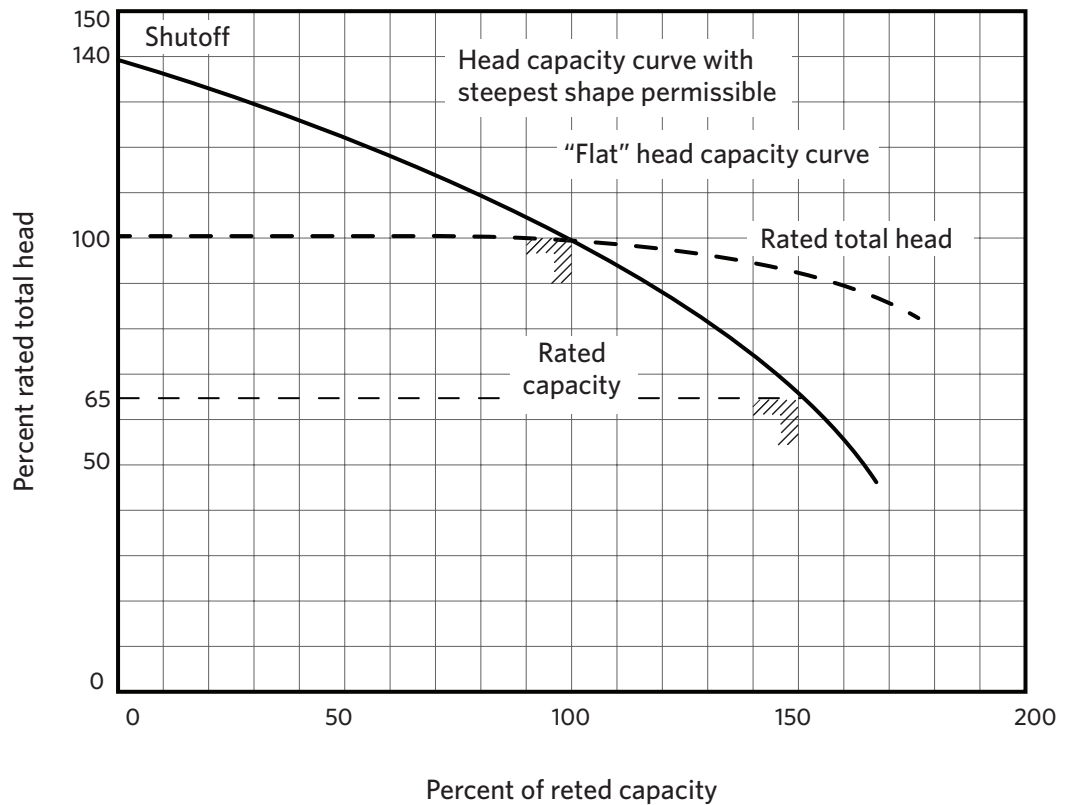

- ▶ As required by NFPA20, each pump is tested at our factory to provide detailed performance data to demonstrate its compliance with the required specifications.
- ▶ In compliance with NFPA20, hydrostatic tests are performed on the pump for a period of not less than 1 minute.
- ▶ Driver rated horse power shall be determined also for operational conditions, where flow rates which are at the order of %150 of the rated flow, are reached.
- ▶ Each pump shall have a label: rated pressure, rated flow, rotational speed and driver service factor being engraved on it.
- ▶ Each pump shall be equipped with pressure gauges that indicate suction and discharge pressure.
- ▶ Pressure relief valve shall be used only where a diesel engine fire pump is installed.
- ▶ Each pump shall be equipped with casing relief valve, to be used for cooling purposes at shut-off pressures.
- ▶ Pump-drive couplings and other movable components must be protected with guards.

# CROSS SECTION DETAILS





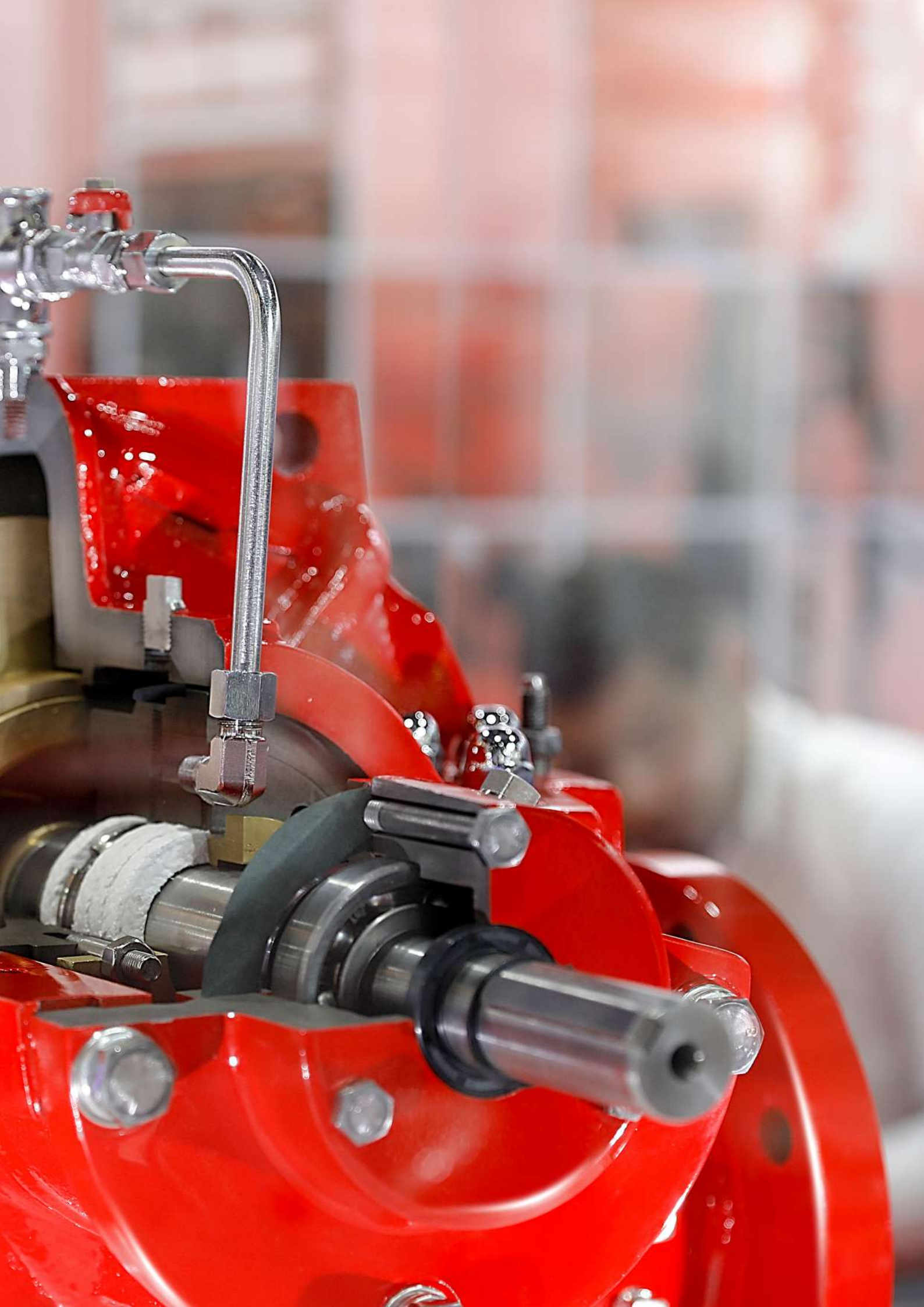

# SPLIT CASE PUMP

## CROSS SECTION DETAILS

### 1. CASING:

The rugged heavy duty, two pieces casing is matched and split horizontally along the centerline of the shaft.

1

### 6. LANTERN RING:

A perforated hollow ring that receives relatively cool, clean liquid. Distribute uniformly around the shaft to provide lubrication and cooling.

6

### 9. BEARING HOUSE:

both the inboard and outboard bearing are protected by lip seals to keep contaminants out of bearing. Completely replaced without disturbing any other part of the rotating assembly.

9

### 4. SHAFT SLEEVE:

Easily replaceable centrifugally cast sleeves protect the shaft from packing wear, and are sealed to prevent leakage. Sleeves are accurately positioned and locked in place.

4

### 2. IMPELLER:

Double suction, enclosed, dynamically and hydraulically balanced prior to the assembly. Impellers are firmly keyed and locked to an accurately finished oversized shaft to absorb all shock loads.

2

### 3. SHAFT:

High strength steel, grounded and polished to a smooth surface, design to transmit full driver horsepower with a liberal safety factor and minimum deflection.

### 8. BEARING:

single-row, cartridge mounting, maintains impeller in their central position, grease type lubrication standard.

### 5. STUFFING BOX:

Accommodate with square rings of packing with a lantern ring. Stuffing box is completely removable and replaceable with rotating assembly.

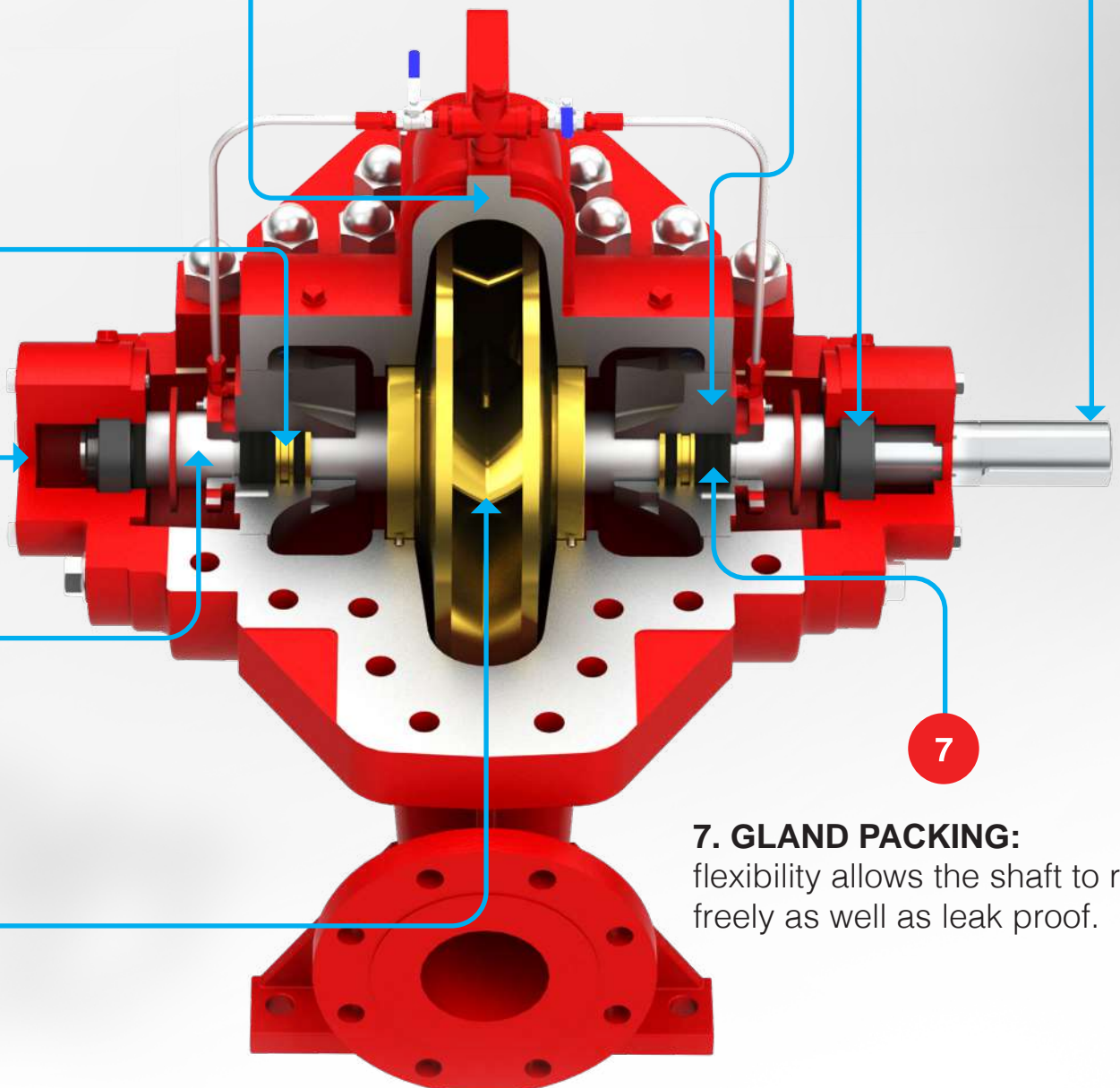

### 7. GLAND PACKING:

flexibility allows the shaft to run freely as well as leak proof.

# END SUCTION

## CROSS SECTION DETAILS

### 10. CASE WEARING RING:

standard enclosed impellers are designed with integral case wear rings to reduce end thrust to a minimum.

10

### 6. LANTERN RING:

A perforated hollow ring that receives relatively cool, clean liquid. Distribute uniformly around the shaft to provide lubrication and cooling.

6

### 1. CASING:

The rugged heavy duty, volute type, top centerline discharge, self venting. Radial split design allows removal of bearing assembly and impeller without disturbing pipe connection.

1

### 2. IMPELLER:

End suction type, enclosed, dynamically and hydraulically balanced prior to the assembly. Impellers are firmly keyed and locked to an accurately finished oversized shaft to absorb all shock loads.

2

### 5. STUFFING BOX:

Accommodate with square rings of packing with a lantern ring. Stuffing box is completely removable and replaceable with rotating assembly.

5

### 3. SHAFT:

High strength steel, grounded and polished to a smooth surface, design to transmit full driver horsepower with a liberal safety factor and minimum deflection.

### 4. SHAFT SLEEVE:

Easily replaceable centrifugally cast sleeves protect the shaft from packing wear, and are sealed to prevent leakage. Sleeves are accurately positioned and locked in place.

### 9. BEARING HOUSE:

both the inboard and outboard bearing are protected by lip seals to keep contaminants out of bearing.

### 8. BEARING:

cartridge mounting, maintains impeller in their central position, grease type lubrication standard.

### 7. GLAND PACKING:

flexibility allows the shaft to run freely as well as leak proof.

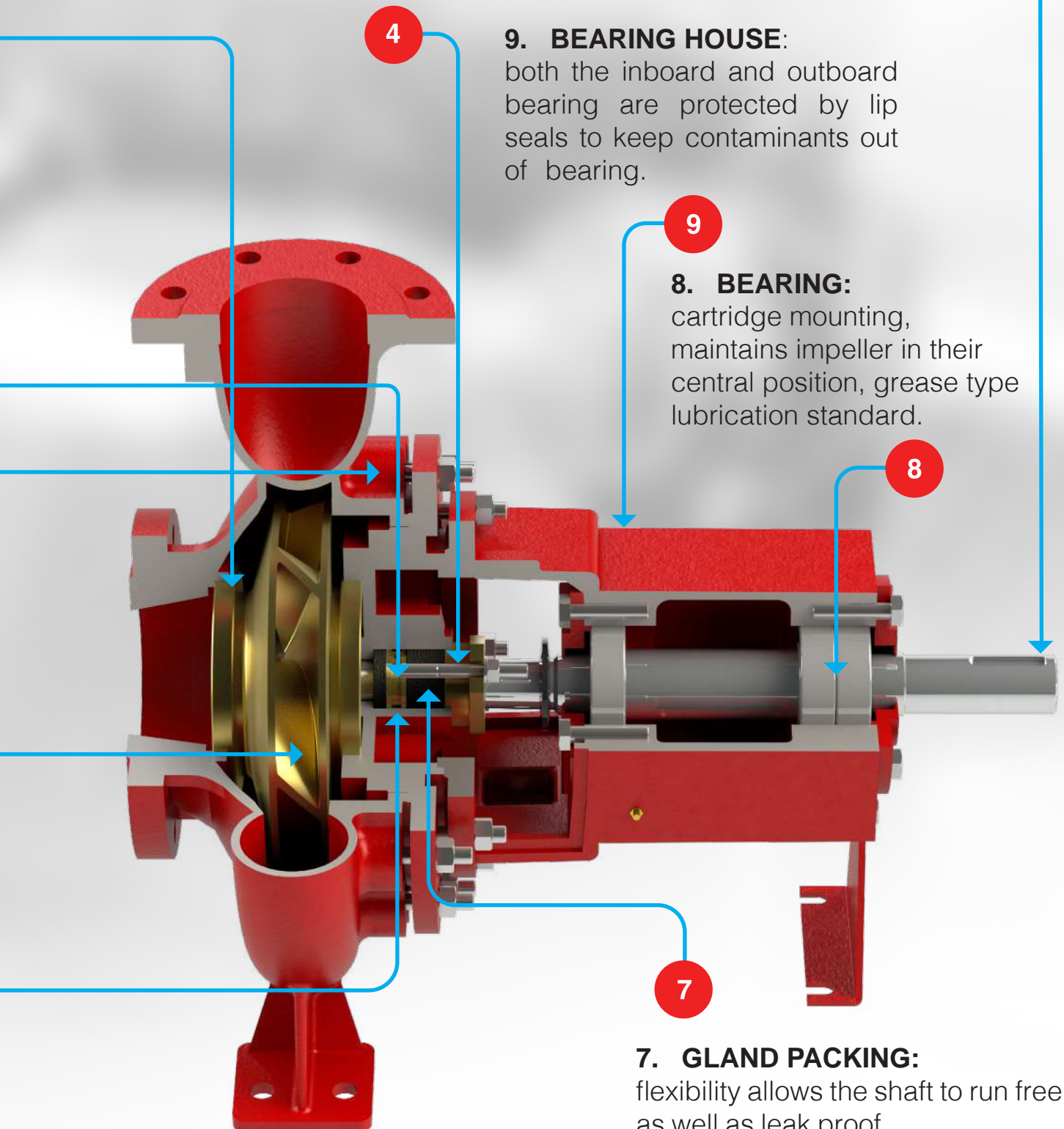

# GENERAL INFORMATION





# SPLIT CASE PUMP

## GENERAL INFORMATION



A black nameplate with a silver border containing technical specifications and logos. The 'waterfall' logo is on the left, and the 'UL LISTED' logo is on the right. The text reads: 'WATERFALL PUMPS MANUFACTURING DUBAI - UAE CENTRIFUGAL FIRE PUMP SPLIT CASE'. Below this are fields for 'MODEL', 'NO. OF STAGES', and 'SERIAL NO.' with the serial number '169052'. Further down are fields for 'RATED B.H.P.', 'MAX B.H.P.', 'MAX SUCT.', and 'P.S.I.'. At the bottom are fields for 'G.P.M.', 'R.P.M.', 'PSIG', 'MAX. PSIG', '1.50 CAP. PSIG', and 'IMP. DIA.'. The nameplate also includes 'Made in UAE'.

		WATERFALL PUMPS MANUFACTURING DUBAI - UAE			
CENTRIFUGAL FIRE PUMP SPLIT CASE					
MODEL		NO. OF STAGES		SERIAL NO.	
				169052	
RATED B.H.P.		MAX B.H.P.		MAX SUCT.	
G.P.M.	R.P.M.	PSIG	MAX. PSIG	1.50 CAP. PSIG	IMP. DIA.
Made in UAE					



## FEATURES:

- ▶ Suction and discharge flanges are on a common center line.
- ▶ Easy access to all working parts.
- ▶ Rugged construction.
- ▶ Efficient operation.
- ▶ Self-venting design.
- ▶ Dynamic balanced Impeller.
- ▶ Performance and hydrostatic test.
- ▶ Space saving design.
- ▶ Available in 50 or 60 Hz.
- ▶ UL / FM

## PUMP DESIGNATION

	WF	5	3	10	HS
Pump Name	WF	5	3	10	HS
Suction nozzle		5	3	10	HS
Discharge nozzle			3	10	HS
Impeller Diameter				10	HS
Pump Type					HS

## TECHNICAL DATA

Suction nozzle	DN 125 – DN 200
Discharge Nozzle	DN 80 – DN 150
Operating Pressure	82 – 346 PSI
Capacity Range	300 – 2000 GPM

**CAUTION**  
DRIVESHAFT MUST BE LUBRICATED  
PRIOR TO START UP AND EVERY  
12 MONTHS FOLLOWING WITH A  
N. L. G. 1 GRADE 1 OR 2 GREASE.  
SEE USER MANUAL FOR MAINTENANCE  
MANUAL FOR CORRECT PROCEDURE

# SPLIT CASE PUMP

## PUMP DIMENSIONS



## Pump - Table of Dimensions (mm)

PUMP MODEL	A	B	Ct	Cs	E	F	G	Ds	Dd	J	L	C	M	N	iØ	K
WF-5X3X10 HS	300	300	270	140	410	170	70	125	80	346	441	315	320	135	35	10x10x78
WF-6X4X12 HS	330	330	345	170	480	200	80	150	100	346	454	355	320	135	35	10x10x78
WF-8X5X11 HS	370	370	310	200	530	225	80	200	125	365	516	400	390	170	45	14x14x108
WF-6X3X14 HS	370	340	310	180	460	190	80	150	80	366	468	333	350	135	35	10x10x78
WF-8X4X16 HS	450	405	365	225	580	240	100	200	100	403	553	380	400	150	45	14x14x108
WF-8X4X17 HS	450	405	362	225	580	240	100	200	100	403	553	425	400	160	45	14x14x108
WF-8X5X14 HS	380	380	270	210	530	225	90	200	125	401	485	400	390	170	44	10x12x104
WF-8X6X11 HS	412	412	270	210	530	225	90	200	150	379	485	400	390	170	44	10x12x104
WF-8X6X14 HS	412	412	270	210	530	225	90	200	150	379	485	400	390	170	49	14x14x104

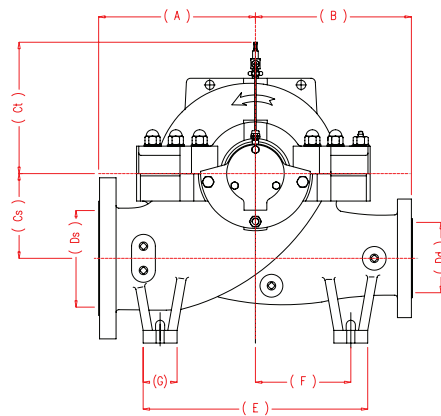

Side View

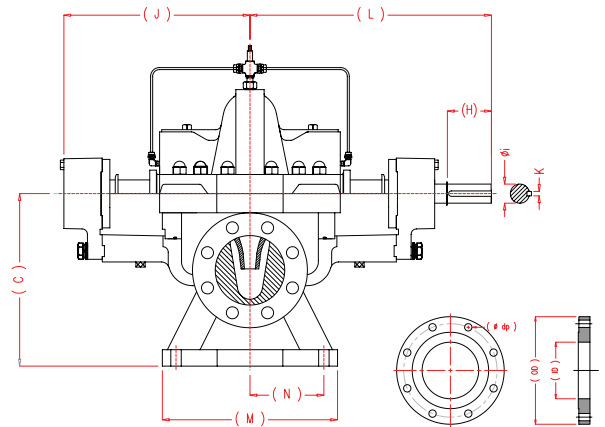

Front View

## Flange - Table of Dimensions (mm)

PUMP MODEL	SUCTION			DISCHARGE		
	ID	OD	dp	ID	OD	dp
WF-5X3X10 HS	125	280	8-holes Ø22 on 235 pcd	80	210	8-holes Ø22 on 168 pcd
WF-6X4X12 HS	150	320	12-holes Ø22 on 270 PCD	100	255	8-holes Ø22 on 200 pcd
WF-8X5X11 HS	200	380	12-holes Ø26 on 330 PCD	125	280	12-holes Ø26 on 235 pcd
WF-6X3X14 HS	150	280	8-holes Ø23 on 241 PCD	80	210	8-holes Ø23 on 168 pcd
WF-8X4X16 HS	200	340	8-holes Ø23 on 298 PCD	100	255	8-holes Ø23 on 200 pcd
WF-8X4X17 HS	200	340	12-holes Ø26 on 330 PCD	100	255	8-holes Ø22 on 200 pcd
WF-8X5X14 HS	200	380	12-holes Ø26 on 330 PCD	125	280	12-holes Ø22 on 235 pcd
WF-8X6X11 HS	200	380	12-holes Ø26 on 330 PCD	150	317	12-holes Ø22 on 270 pcd
WF-8X6X14 HS	200	380	12-holes Ø26 on 330 PCD	150	317	12-holes Ø22 on 270 pcd

# END SUCTION PUMP

## GENERAL INFORMATION



## FEATURES:

- ▼ Easy access to all working parts. Rugged construction.
- ▼ Efficient operation.
- ▼ Self-venting design.
- ▼ Dynamic balanced Impeller.
- ▼ Performance and hydrostatic test.
- ▼ Space saving design.
- ▼ Available in 50 or 60 Hz.
- ▼ UL

### PUMP DESIGNATION

	WF	3	10	ES
Pump Name _____	WF			
Discharge nozzle _____		3		
Impeller Diameter _____			10	
Pump Type _____				ES

### TECHNICAL DATA

Suction nozzle	DN 65 – DN 125
Discharge Nozzle	DN 40 – DN 100
Operating Pressure	73 – 309 PSI
Capacity Range	50 – 1000 GPM

# END SUCTION PUMP DIMENSIONS



## Pump - Table of Dimensions (mm)

PUMP MODEL	A	B	C	D	E	Ee	F	G	H	K	L	M	iØ	J
WF-1.5X10X ESF	100	507	225	180	125	65	95	370	325	250	110	80	32	10x10x56
WF- 2X10 ESF	120	507	225	180	125	65	95	370	325	250	110	80	32	10x10x56
WF-2.5X10X ESF	130	497	250	200	163	84	120	370	365	280	110	80	32	10x10x56
WF- 3X10 ESF	130	497	280	230	163	84	120	382	365	315	110	80	32	10x10x56
WF- 3X12 ESF	125	540	317	250	160	80	110	377	400	315	110	110	42	10x12x80
WF- 3X12 ES	125	513	315	250	160	80	120	360	400	315	114	110	42	8x12x54.6
WF- 4X10 ES	140	515	280	225	165	80	120	370	400	315	114	107	42	8x12x54.6
WF- 4X12 ESF	140	532	317	250	160	80	110	377	400	315	110	110	42	10x12x80
WF- 4X12 ES	140	517	315	250	166	80	120	370	400	315	110	110	42	8x12x54.6

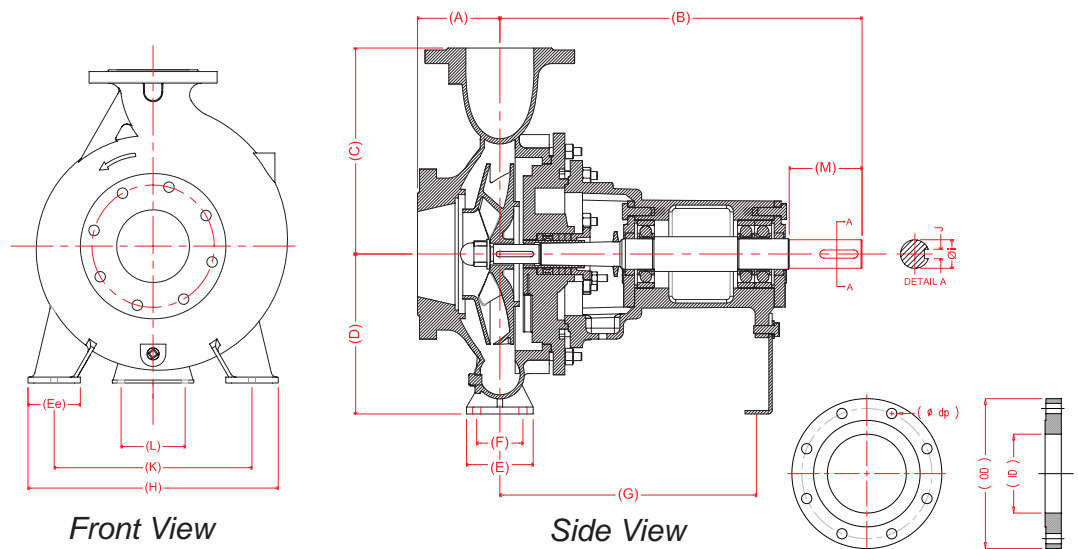

## Flange - Table of Dimensions (mm)

PUMP MODEL	SUCTION			DISCHARGE		
	Ø ID	Ø OD	Ø DP	Ø ID	Ø OD	Ø DP
WF- 1.5X10 ESF	65	178	4-holes Ø19 on pcd 140	40	127	4-holes Ø16 on pcd 98.5
WF- 2X10 ESF	80	190	4-holes Ø19 on pcd 152	50	152	4-holes Ø18.5 on pcd 121
WF- 2.5X10 ESF	100	228	4-holes Ø19 on pcd 190	65	177	4-holes Ø19 on pcd 139
WF- 3X10 ESF	125	255	4-holes Ø19 on pcd 215	80	190	4-holes Ø19 on pcd 152
WF- 3X12 ESF	125	279	8-holes Ø22 on pcd 235	80	210	8-holes Ø22 on pcd 168
WF- 3X12 ES	100	220	8-holes Ø17 on pcd 180	80	200	8-holes Ø17 on pcd 160
WF- 4X10 ES	125	250	8-holes Ø17 on pcd 210	100	220	8-holes Ø17 on pcd 180
WF- 4X12 ESF	125	279	8-holes Ø22 on pcd 235	100	253	8-holes Ø22 on pcd 200
WF- 4X12 ES	125	250	8-holes Ø17 on pcd 210	100	220	8-holes Ø17 on pcd 180

# PUMP ROOM ARRANGEMENT

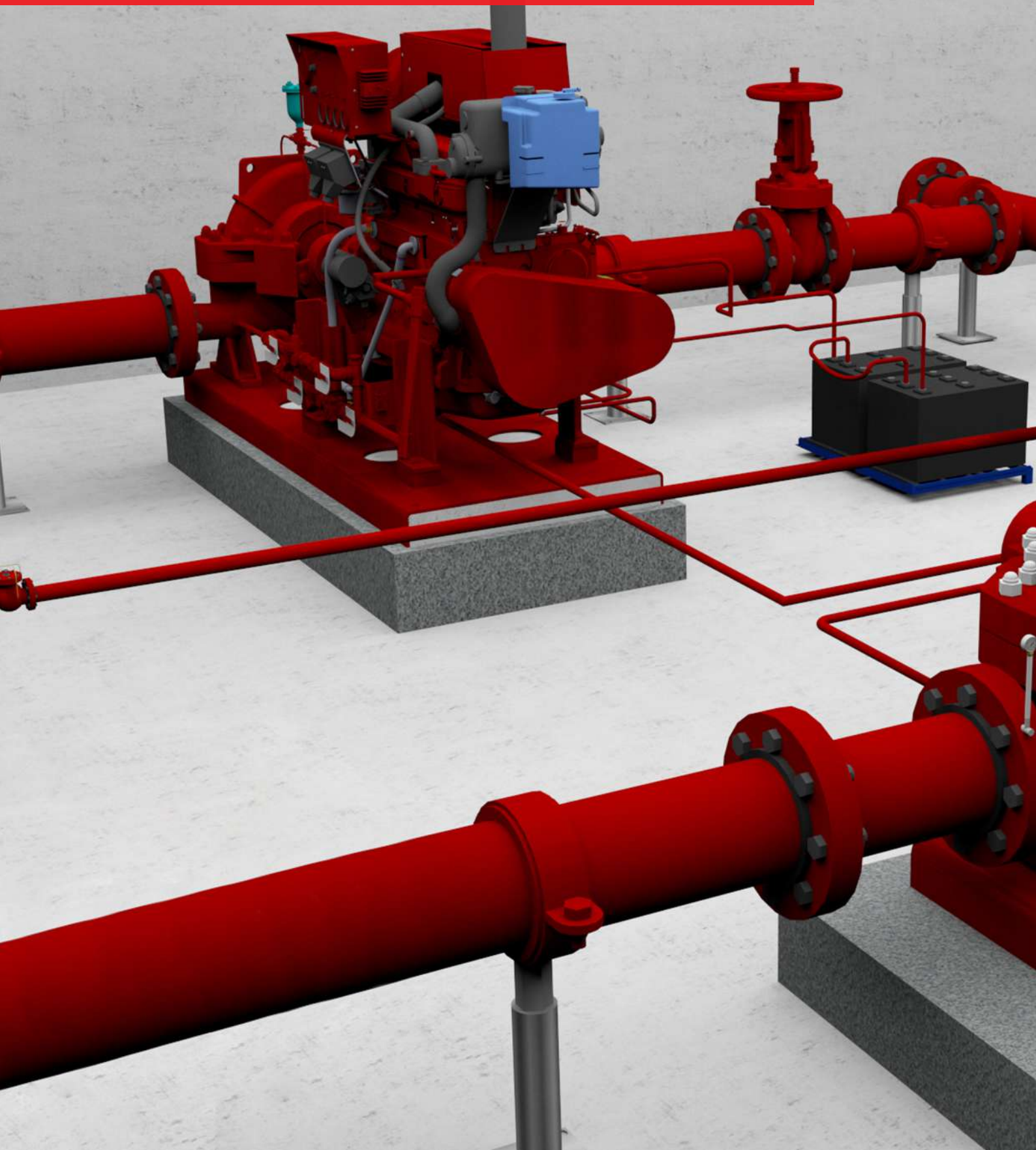



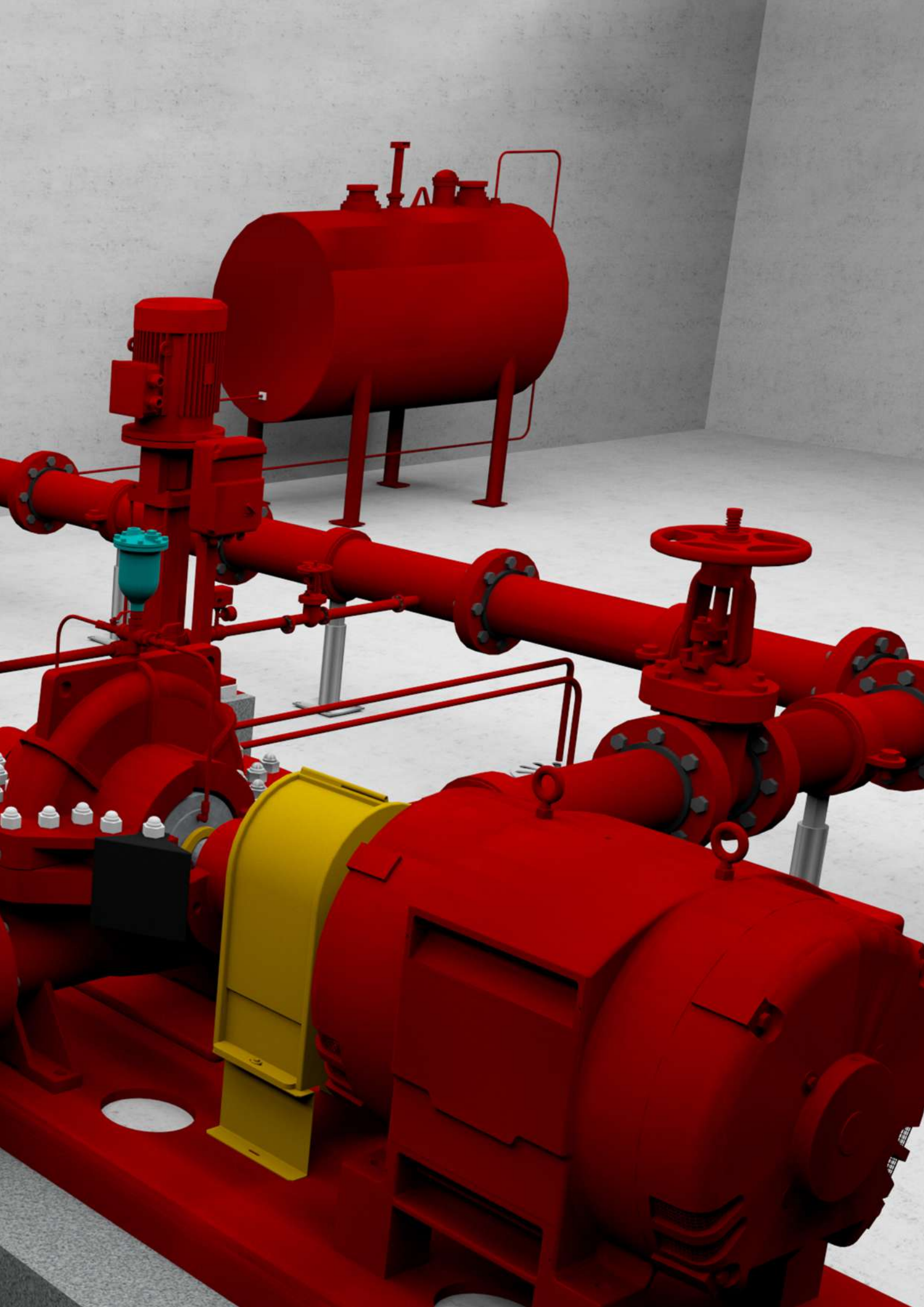

# ELECTRIC DRIVEN PUMP SPLIT CASE PUMP

## DESIGN POINTS

### 1.Pump:

The Fire Pump shall furnish not less than %150 of rated capacity at a pressure not less than %65 of rated head. The Shut off total head of the pump should not exceed %140 of total rated head. A certified test curve, indicating the flow, head, power, and efficiency shall be supplied.

Each pump shall withstand a hydrostatic pressure test of 2 times the maximum working pressure or 400 PSI, whichever is greater for a period of 5 minutes.

Waterfall pumps, is listed by Underwriters Laboratories Inc. (UL) and Approved by Factory Mutual(FM).

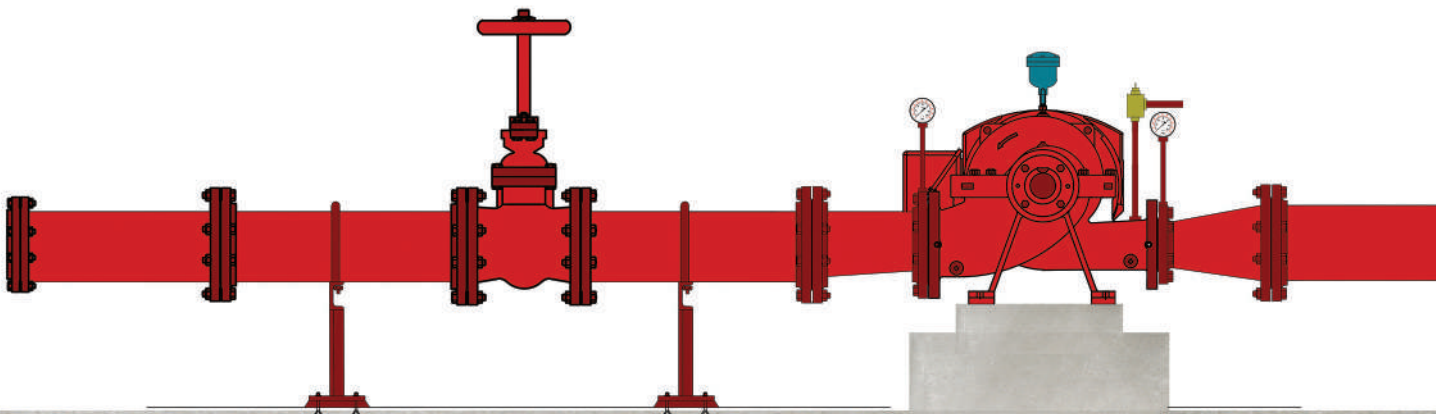
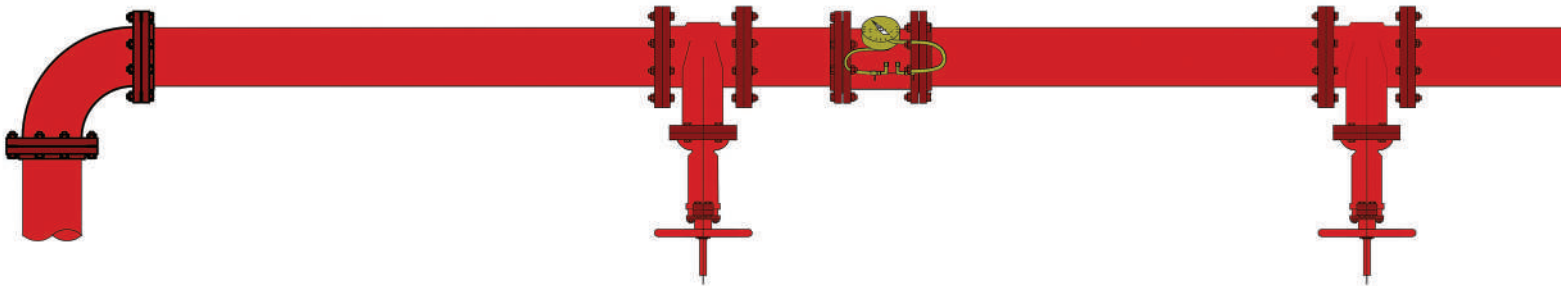

## 2. Motor:

UL listed electric motor shall be coupled directly to the fire pump through flexible coupling. The maximum pump break horsepower shall not exceed the HP rating of its driver, including service factor. Motor shall be standard efficiency with 1.15 service factor.

## 3. Controllers:

The main fire pump controller shall be a factory assembled, wired, and tested unit and shall conform to all the requirements of the latest edition of NFPA 20, Standard for the Installation of Stationary Pumps for Fire Protection and NFPA 70, National Electrical Code.

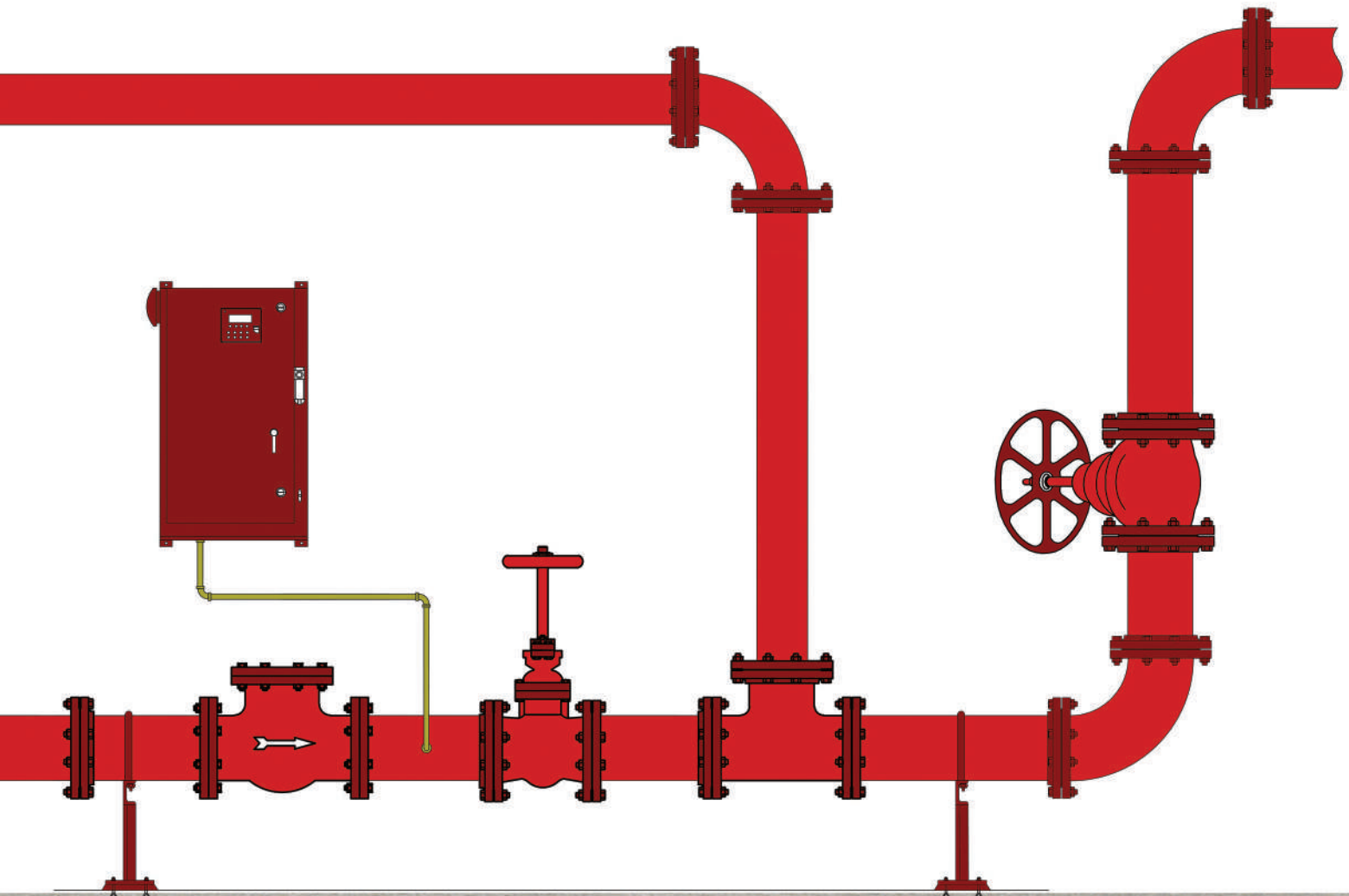

# DIESEL DRIVEN PUMP SPLIT CASE PUMP

## DESIGN POINTS

### 1.Pump:

The Fire Pump shall furnish not less than %150 of rated capacity at a pressure not less than %65 of rated head. The Shut off total head of the pump should not exceed %140 of total rated head. A certified test curve, indicating the flow, head, power, and efficiency shall be supplied.

Each pump shall withstand a hydrostatic pressure test of 2 times the maximum working pressure or 400 PSI, whichever is greater for a period of 5 minutes.

Waterfall pumps, is listed by Underwriters Laboratories Inc. (UL) and Approved by Factory Mutual(FM).

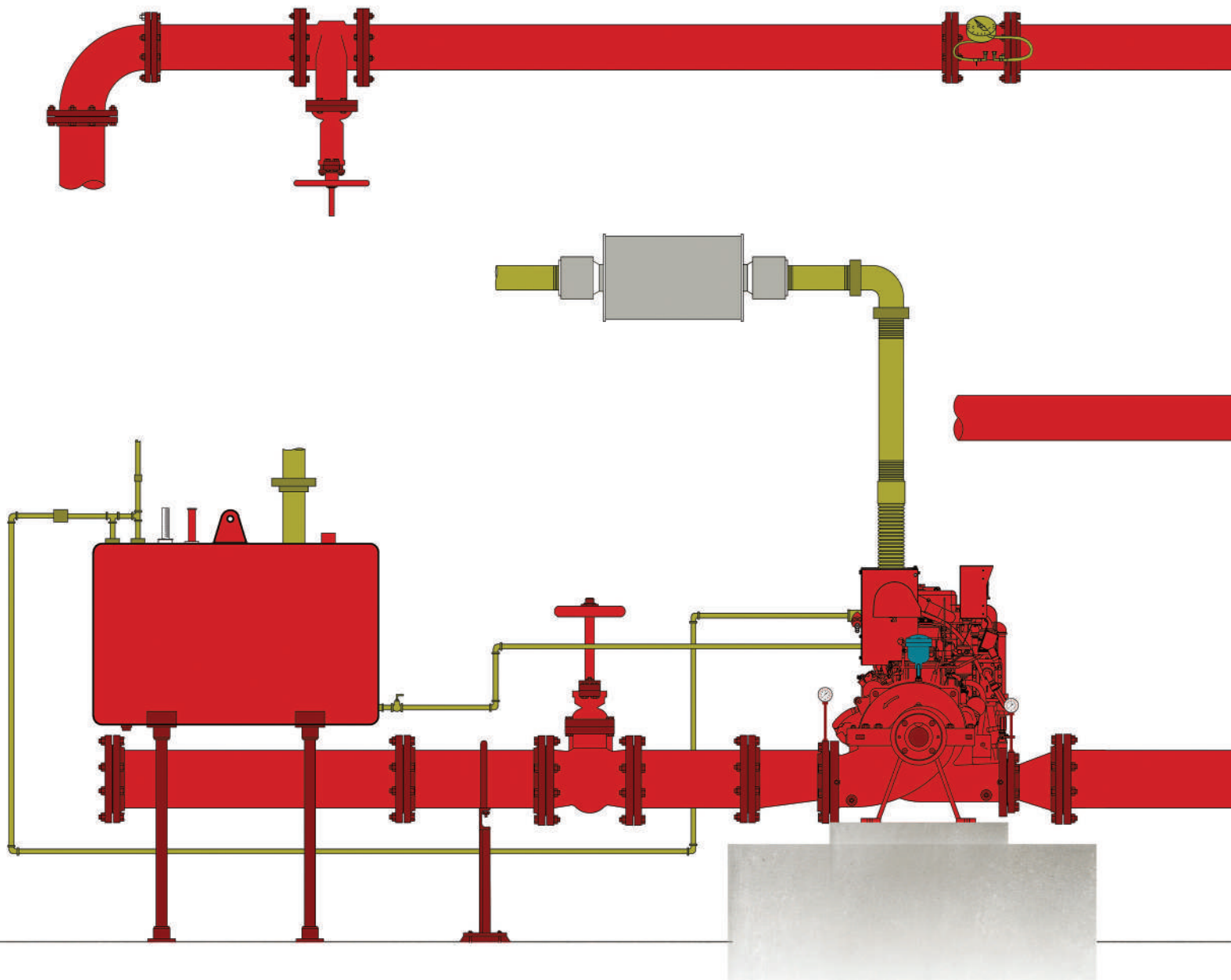

## 2. Engine:

The engine shall be UL / FM approved. The engine shall have a deduction %3 for every 1000ft. At SAE condition for altitude above 300ft. and %1 for every 10 °F ( 5.6 °C ) degrees above 77 °F degrees (25degrees °C ) ambient temperature.

The engine shall be of adequate horsepower to be non-overloading through our the pump maximum design requirements.The engine shall be 24/12 Volt operational

## 3. Controllers

The fire pump controller shall be a factory assembled, wired and tested unit and shall conform to all the requirements of the latest edition of NFPA 20, Standard for the Installation of Stationary Pumps for Fire Protection and NFPA 70, National Electrical Code.

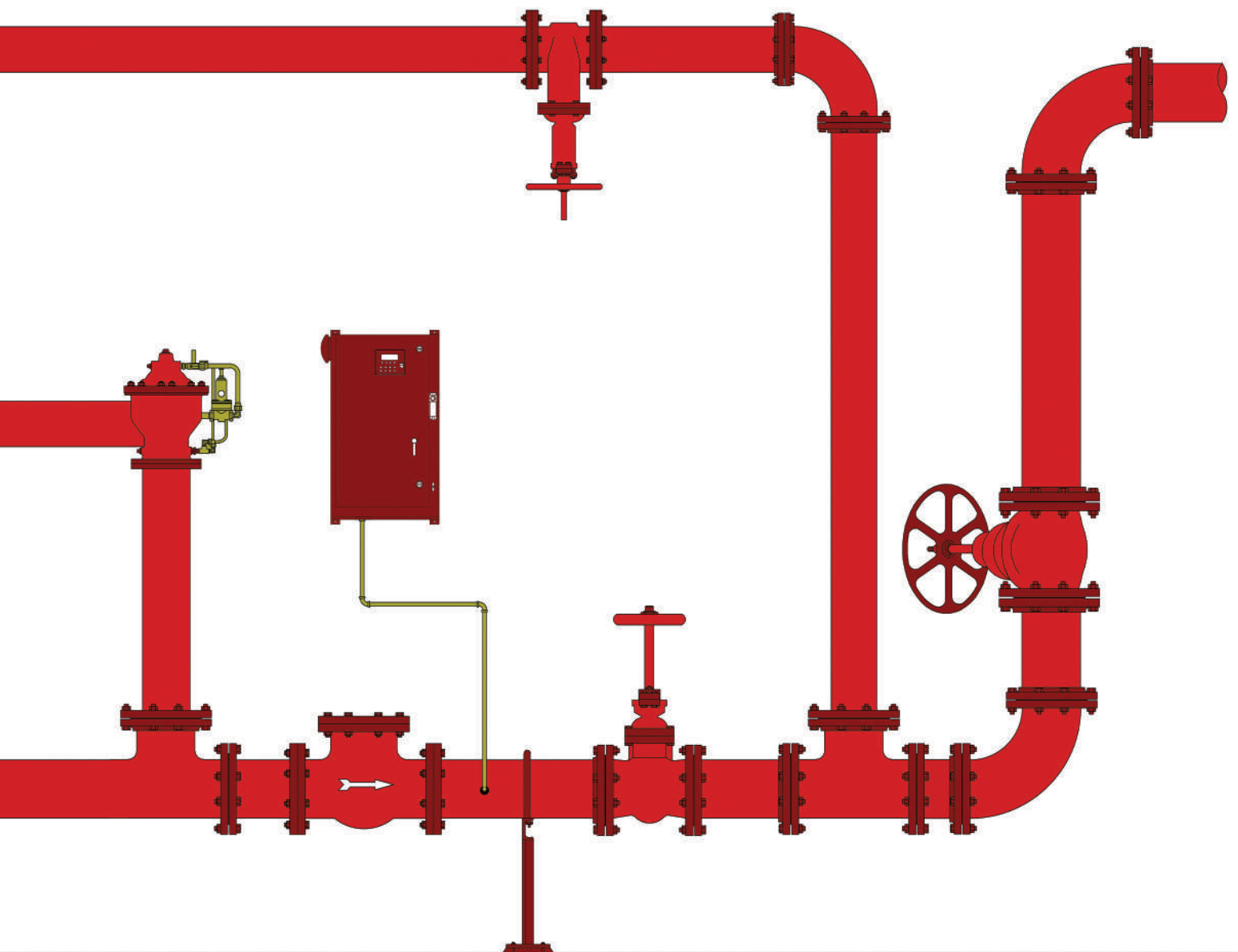

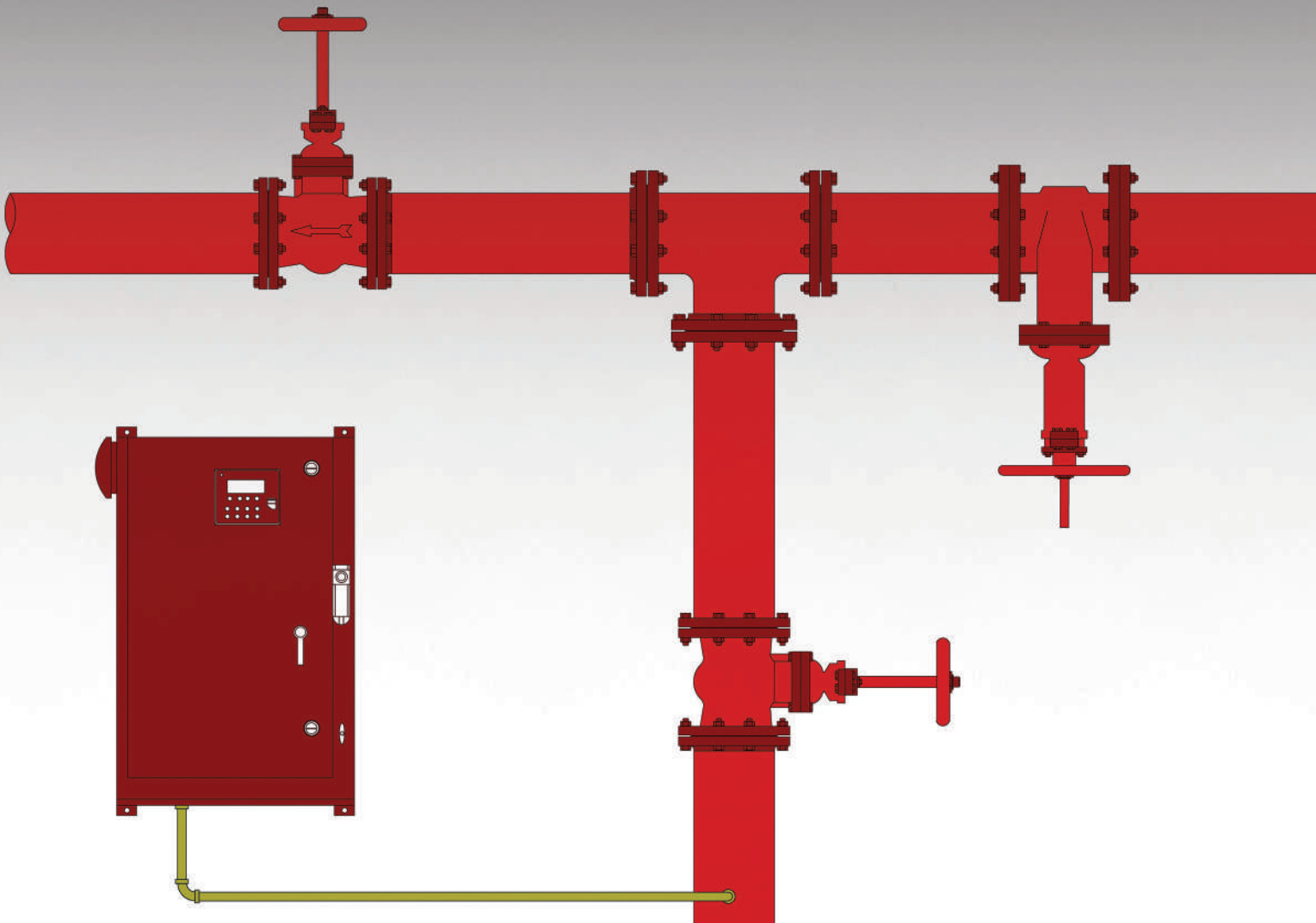

**ELECTRIC  
DRIVEN PUMP  
END SUCTION**

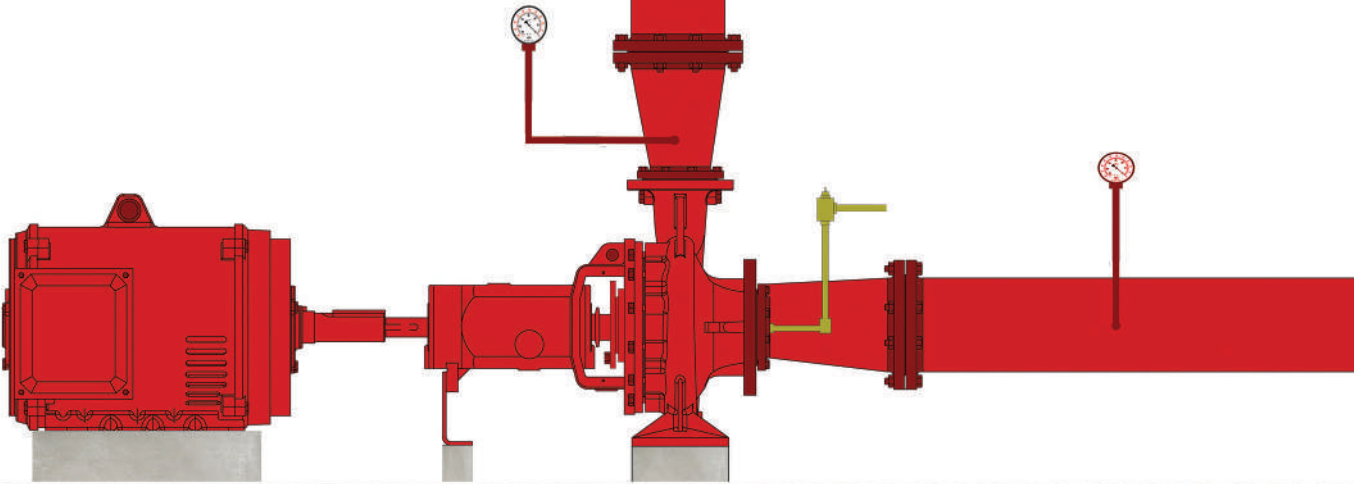

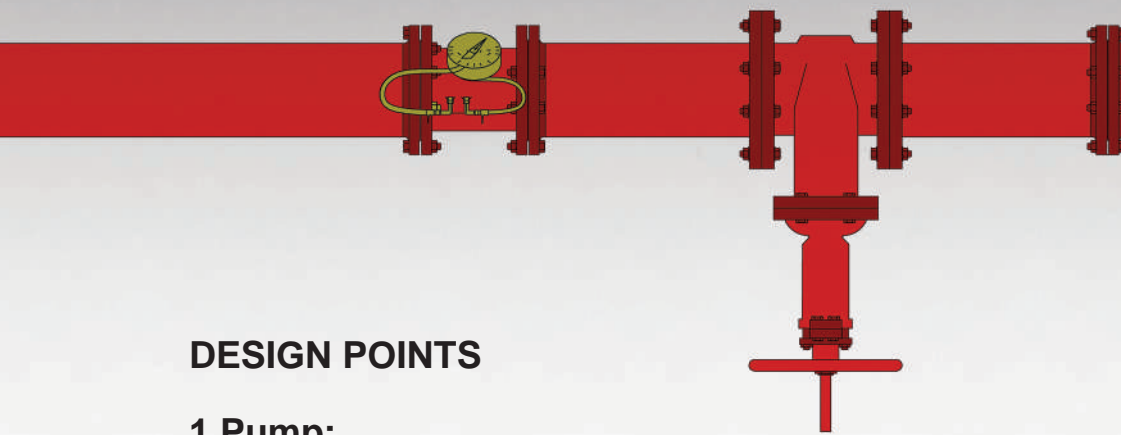

## DESIGN POINTS

### 1. Pump:

The Fire Pump shall furnish not less than %150 of rated capacity at a pressure not less than %65 of rated head. The Shut off total head of the pump should not exceed %140 of total rated head. A certified test curve, indicating the flow, head, power, and efficiency shall be supplied.

Each pump shall withstand a hydrostatic pressure test of 2 times the maximum working pressure or 400 PSI, whichever is greater for a period of 5 minutes.

Waterfall pumps, is listed by Underwriters Laboratories Inc. (UL) and Approved by Factory Mutual(FM).

### 2. Motor:

UL Listed electric motor shall be coupled directly to the fire pump through flexible coupling. The maximum pump brake horsepower shall not exceed the HP rating of its driver, including service factor. Motor shall be standard efficiency with 1.15 service factor.

### 3. Controllers:

The main fire pump controller shall be a factory assembled, wired, and tested unit and shall conform to all the requirements of the latest edition of NFPA 20, Standard for the Installation of Stationary Pumps for Fire Protection and NFPA 70, National Electrical Code.

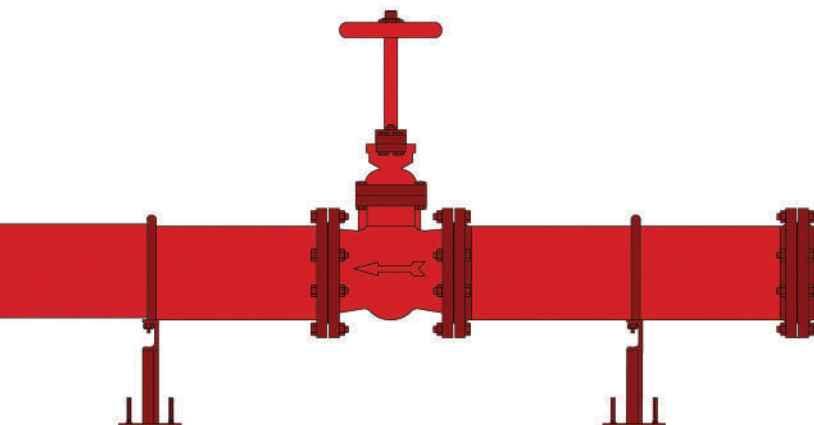

# DIESEL DRIVEN PUMP END SUCTION

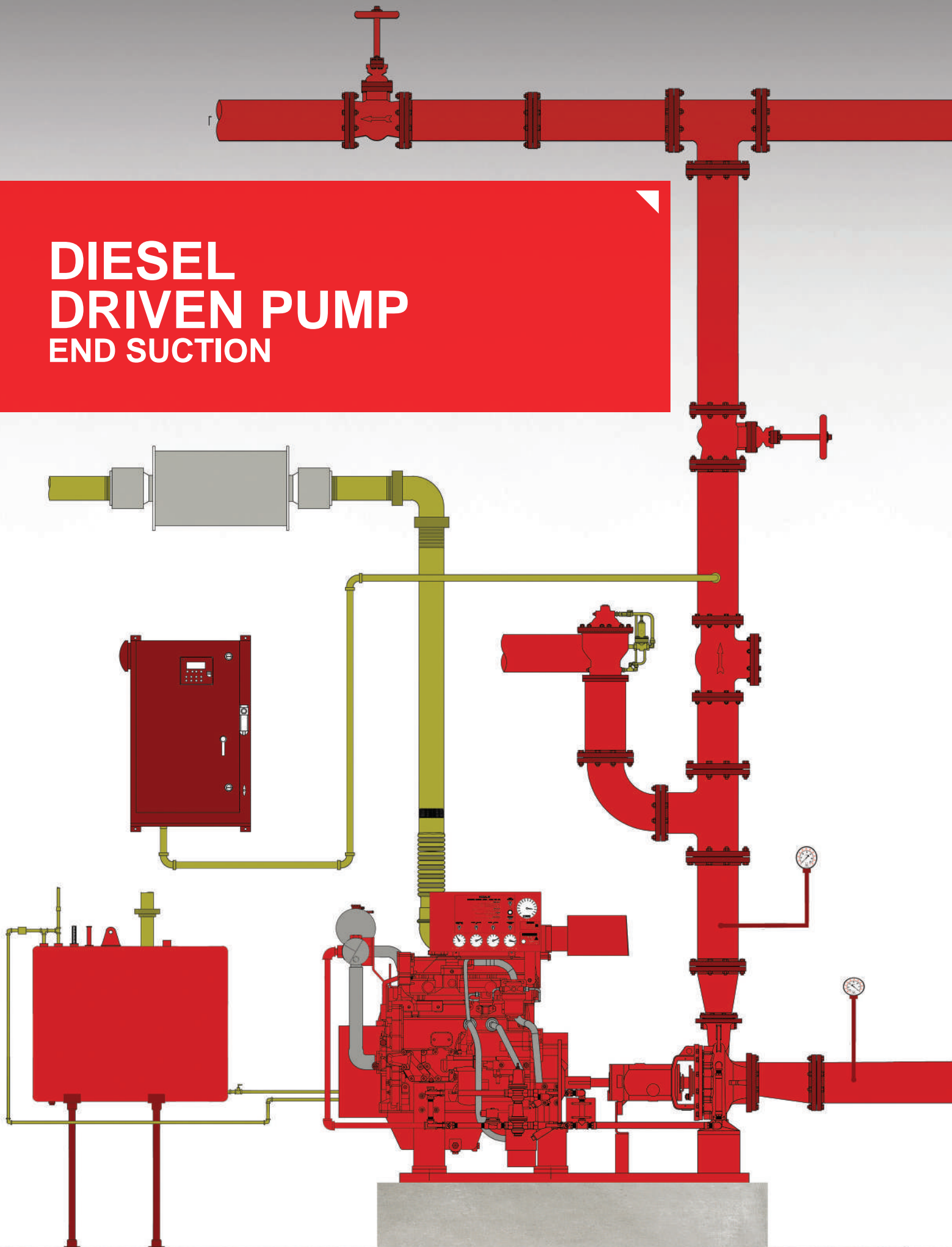



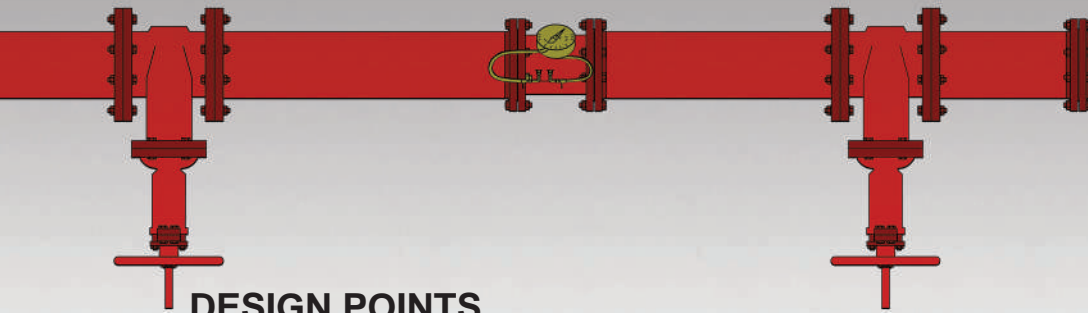

## DESIGN POINTS

### 1. Pump:

The Fire Pump shall furnish not less than %150 of rated capacity at a pressure not less than %65 of rated head. The Shut off total head of the pump should not exceed %140 of total rated head. A certified test curve, indicating the flow, head, power, and efficiency shall be supplied.

Each pump shall withstand a hydrostatic pressure test of 2 times the maximum working pressure or 400 PSI, whichever is greater for a period of 5 minutes.

Waterfall pumps, is listed by Underwriters Laboratories Inc. (UL) and Approved by Factory Mutual (FM).

### 2. Engine:

The engine shall be UL / FM approved. The engine shall have a deduction %3 for every 1000ft. At SAE condition for altitude above 300ft. and %1 for every 10 °F ( 5.6 °C ) degrees above 77 °F degrees ( 25degrees °C ) ambient temperature.

The engine shall be of adequate horsepower to be non-overloading through our the pump maximum design requirements. The engine shall be 24/12 Volt operational

### 3. Controllers:

The fire pump controller shall be a factory assembled, wired and tested unit and shall conform to all the requirements of the latest edition of NFPA 20, Standard for the Installation of Stationary Pumps for Fire Protection and NFPA 70, National Electrical Code.

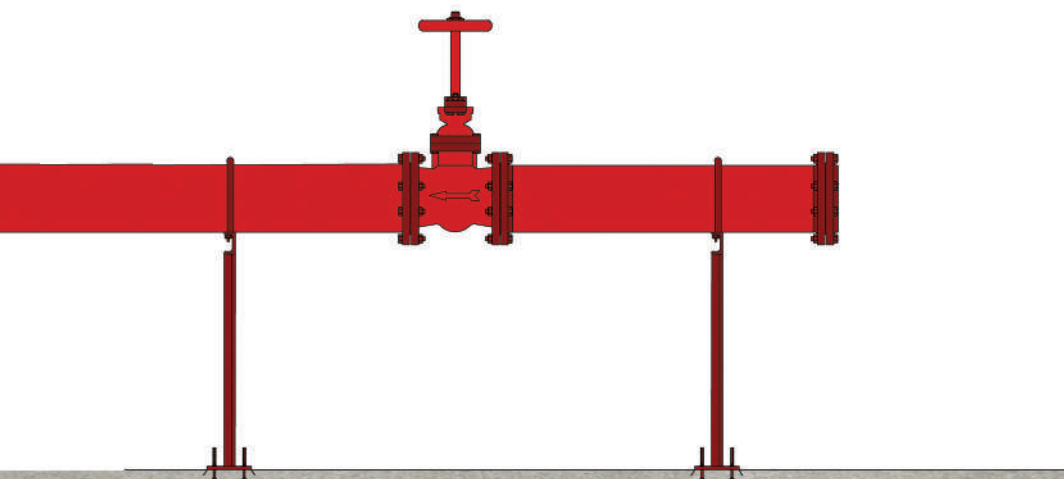

A close-up photograph of a red circular object, possibly a metal flange or a large button, featuring a central red oval. The oval contains the white lowercase letters 'wf' in a bold, rounded font. Below the letters, the word 'waterfall' is written in a smaller, white, sans-serif font. The background of the object is red and has several dark, circular holes arranged in a ring around the central oval.

**wf**

waterfall



**“Waterfall pumps remains committed to designing & developing innovative products to serve the clients’ needs”**

